

CIS - Centrul pentru Iluminat cu Semiconductori (Semiconductors Lighting Center)

**TECHNICAL SHEET
 LED Luminary – CASTOR 2M**

| | |
|------------------------------------|---------------------------|
| Code | RS81455 |
| Application | Industrial |
| Operating voltage | 230 V ~ |
| Mains frequency | 50 Hz |
| Power consumption | 63 W ± 10 % |
| Power Factor (λ) | > 0.92 |
| Total Harmonic Distortions | < 20 % |
| Insulation class | I |
| Luminous Flux | min. 6000 lm |
| Color temperature (CCT) | (5600 K) |
| Color rendering index (IRC) | > 80 |
| Optical / material | lens C |
| Ingress protection | IP65 |
| Mechanical Shock | IK10 |
| Operating temperature range | max. +45 °C |
| Weight | 4,2 Kg |
| Dimensions (L x W x H) | 380 x 225 x 303 mm |

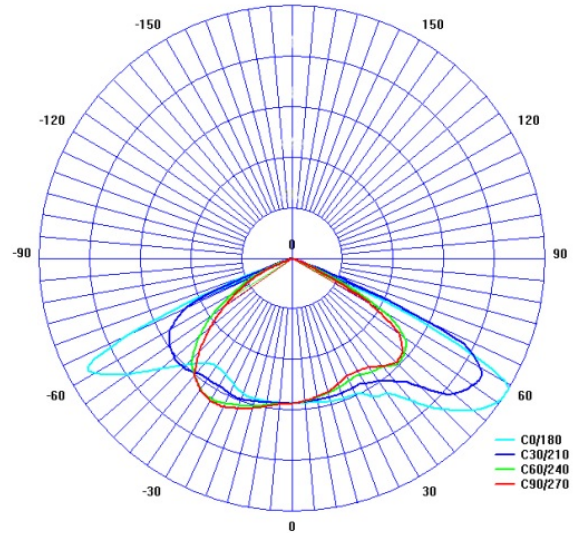

Light Distribution Diagram

Shape and dimensions:

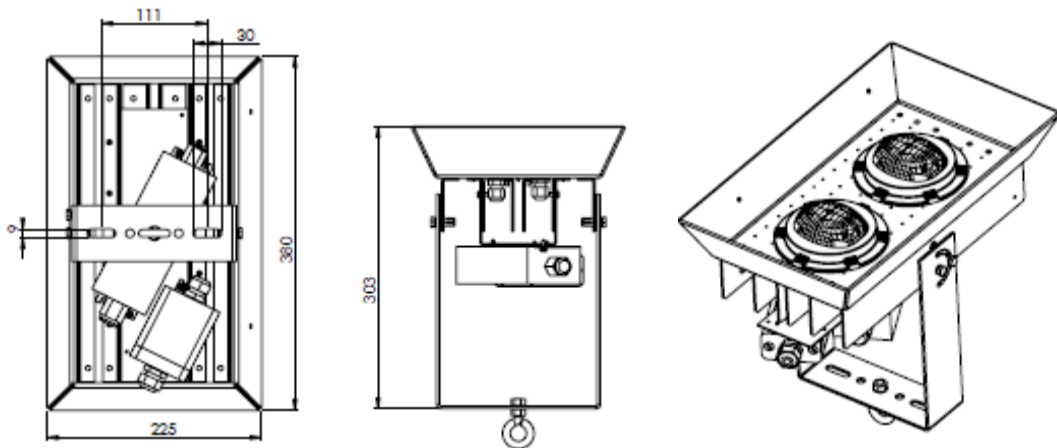

Applicable Standards:

- SR EN 60598-1:2009+A11:2009
- SR EN 60598-2-5:2001
- SR EN 62031:2009 art.13, 15
- SR EN 55015:2007+A1:2008+A2:2009
- SR EN 61000-3-2:2006+A1:2010+A2:2010
- SR EN 61000-3-3:2009
- SR EN 61547:2010